

@ timerinterval

L:xxx;R:xxx;

xxx = data 0-255

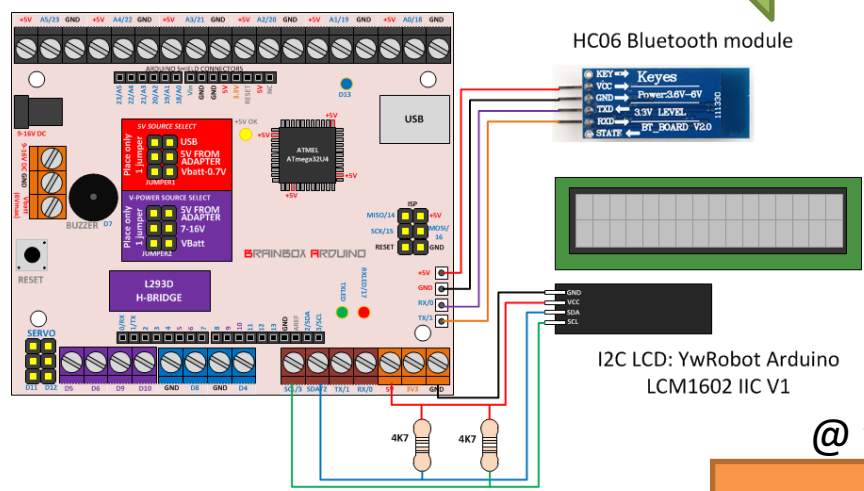

@ timerinterval x 2

xxx | yyy | zzzz |

xxx = data 0-100

yyy = data 0-255

zzz = data 0-1024